



PHII AND PHEII MARINE TOILETS

INSTALLATION AND MAINTENANCE INSTRUCTIONS

THE FOLLOWING ARE CAUTIONARY STATEMENTS THAT MUST BE READ AND FOLLOWED DURING BOTH INSTALLATION AND OPERATION

WARNING:  *Raritan Engineering Company, Inc. recommends that a qualified person or electrician in the case of PHEII, install this product. Equipment damage, injury to personnel or death could result from improper installation. Raritan Engineering Company, Inc. accepts no responsibility or liability for damage to equipment, or injury or death to personnel, that may result from improper installation or operation of this product.*

WARNING:  **Hazard of Flooding** - Any installation made below the waterline must have vented loops positioned properly and all hose connections should be double-clamped. Both intake and discharge seacocks should always be in the closed position when the toilet is not in use. Failure to do so may result in flooding, property damage and loss of life.

WARNING:  Do not operate PHEII series toilets with handle in place, serious bodily injury may occur.

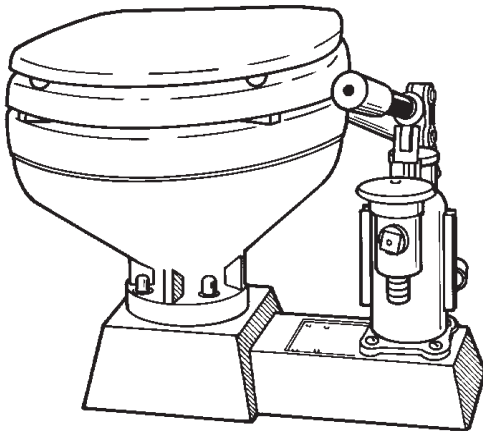

The PHII is a manually operated double action piston toilet. The PHII can be converted to its electrical counterpart by adding an electrical conversion kit part# PHECKII*.

*Specify Voltage

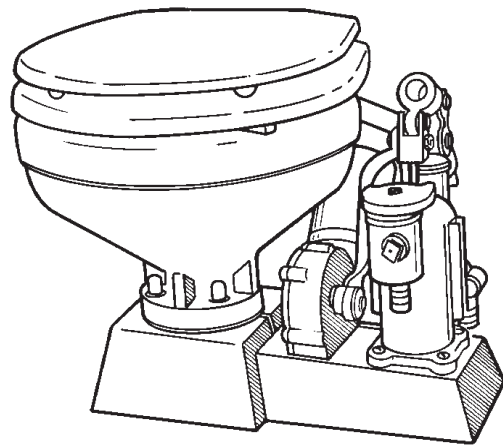

The PHEII is the electric version which incorporates an electric motor driven gear box.

Model and Serial Number:

All models are suitable for use in conjunction with Raritan's Electroscan[®] and Purasan[®]. Both are U.S. Coast Guard Certified Type I flow-thru Marine Sanitation Device (MSD) and/or holding tanks.



1-856-825-4900

www.raritaneng.com

OPERATION

WARNING: DO NOT adjust valve handle (1209BW) while toilet is operating.

1. With valve handle in the "FLUSH" position pumping the handle (or pressing the button on electric units) will draw water in and discharge the bowl contents.
2. With valve handle in the "DRY" position pumping the handle (or pressing the button) will only discharge the bowl contents while drawing air in through the air valve assembly to prevent a build-up of pressure.
 - We recommend single ply toilet paper.
 - Water should appear in the bowl within ten seconds. If not, see troubleshooting section.
 - Hard objects or stringy substances (paper towels, feminine hygiene products, filter cigarettes, etc.) must not be thrown into the toilet as they will cause damage.
 - Always shut off seacock(s) before leaving the boat unattended.

Valve handle must be *fully* in the "FLUSH" or "DRY" position only.



Position for intake of water and discharge of bowl contents

RETURNING PHEII TO MANUAL OPERATION

WARNING: Secure circuit breaker in "OFF" position before proceeding.

1. Remove arm bolt and nut (#1115 and #1115A) from the top of the connecting rod (#1116BW).
 2. Displace connecting rod (#1116BW) from track.
 3. Insert the handle (#1208W) and cotter pin (#1210A).
- To return to electrical operation, reverse procedure.

Cleaning Instructions

IMPORTANT: Do not use cleaners that contain ammonia, ethyl acetate, phosphoric acid or concentrated chlorine bleach. These may cause damage to the toilet.

Using C.P. a bio-enzymatic toilet bowl cleaner (available from Raritan Engineering) will keep the bowl clean and fresh smelling.

Recommend Visual Inspection

- ✓ For leaks at toilet and hose connections
- ✓ Hose clamps
- ✓ Condition of hoses
- ✓ Seacocks
- ✓ Condition of wires and connections
- ✓ In-Line Strainer (if you have one)



Position for discharge of bowl contents only (no water coming in)

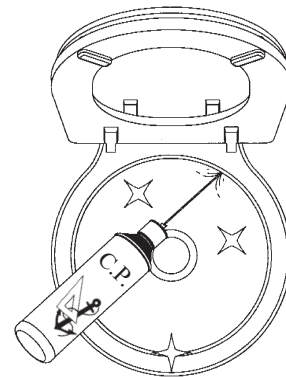

MAINTENANCE

Super Lube® (#SL1CC) applied to the piston rod will prolong the life of the Piston Shaft Seal. This should be done every spring and fall or more regularly if the head is used frequently. Applying Super Lube to all moving parts is also recommended.

Installation of a Knocks Out Odor Kit (#KO2) will reduce the "rotten egg" smell associated with using salt or brackish water to flush the toilet.

Before attempting repairs, refer to the Troubleshooting section of this manual.

WINTERIZING

Improper winter lay up is a major cause of marine toilet failures.

Parts Required

- 3/4" I.D. intake hose approximately 3 feet long.
 - 1 1/2" I.D. discharge hose approximately 3 feet long.
 - Two buckets
 - Nontoxic antifreeze approximately 1 quart
1. Close the intake and discharge seacock. Disconnect and drain the intake and discharge hoses.
 2. Connect short hoses to toilet's intake and discharge.
 3. Place one bucket under short hose on discharge.
 4. Pour nontoxic antifreeze in other bucket.
 5. Place hose connected to intake into bucket with antifreeze.
 6. Flush toilet until antifreeze begins to be discharged from toilet.
 7. Antifreeze should remain in the toilet until recommissioning. This will protect both intake and discharge sides of the pump. Pouring antifreeze into the bowl will only protect the discharge.

NOTE: Holding tanks, seacocks and treatment systems need to be independently winterized, stored and recommissioned (see manufacturer's instructions).

RECOMMISSIONING

1. Lubricate piston rod with Super Lube®.
2. Using the buckets, hoses and a gallon (3.8 liters) of clean water, flush the antifreeze out of the toilet. Dispose of antifreeze properly, in accordance with local and federal regulations.
3. Reconnect the hoses and open both seacocks.
4. Check all connections for leaks with several test flushes.

INSTALLATION OF REPLACEMENT PARTS

1. Refer to Fig. #2 when replacing part #1228CW.
2. If valve body (#1203BW) is removed it must be positioned as in Fig. #3 for proper operation.

Overhaul kits and individual parts for your toilet may be ordered through your dealer or direct from the factory.

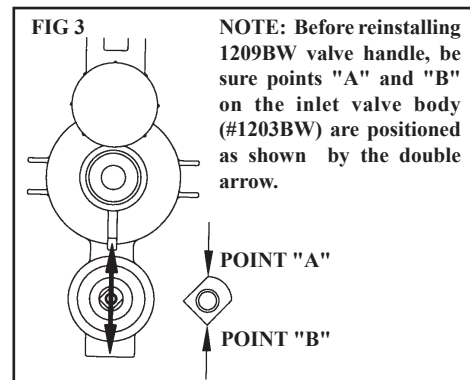
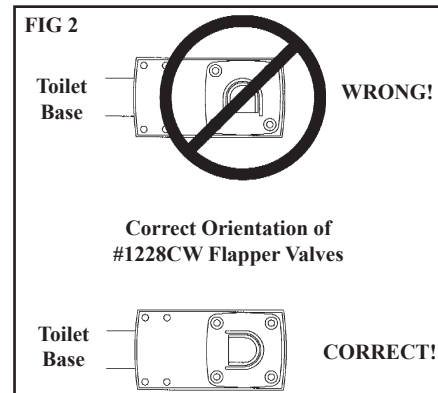

Tools Required

- 5/16" nut driver
- Wrench or screw driver
- Bit for drilling mounting surface
- Hose cutters
- Tape measure

Additional Parts Required

- Four stainless steel mounting bolts or lag screws (minimum 1/4" [6mm]) and washers
- 1 1/2" I.D. discharge hose
- 3/4" I.D. reinforced intake hose
- Hose clamps (two for each connection below waterline)

PHEII Units Require

- Wire
- Wire cutters
- Wire terminal crimpers
- Terminals
- Fuse/circuit breaker

SPECIFICATIONS

Electrical

Nominal Voltage (Volts DC)	12V	24V	32V
Amperage Draw @ Nominal Voltage	18	11	8
Circuit Breaker/Fuse Size (Amps)	25	20	12

Wire Sizes

NOTE: Recommended conductor sizes based on 105C rated insulation.

Refer to ABYC Standards for other insulation ratings.

UNIT'S VOLTAGE	Distance from source to unit and back to source [feet (m)]						
	10' (3.1)	15' (4.6)	20' (6.1)	25' (7.2)	30' (9.2)	40' (12.2)	50' (15.2)
	Minimum recommended conductor wire AWG (mm ²) for 3% voltage drop						
12	10 (6.0)	10 (6.0)	8 (10.0)	6 (16.0)	6 (16.0)	6 (16.0)	4 (25.0)
24	16 (1.5)	14 (2.5)	12 (4.0)	12 (4.0)	10 (6.0)	10 (6.0)	8 (10.0)
32	16 (1.5)	16 (1.5)	16 (1.5)	14 (2.5)	14 (2.5)	12 (4.0)	12 (4.0)

Raritan PHII / PHEII Marine Toilet Front View, Side View and Footprint

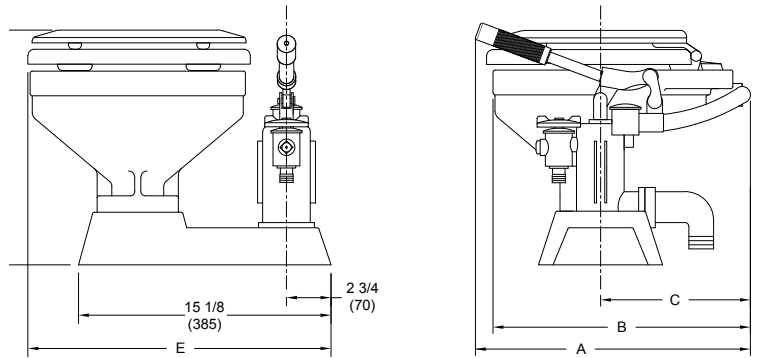

BOWL TYPE	A	B	C	D	E
MARINE	17 3/8 (442)	17 (432)	10 (254)	14 1/4 (362)	18 (458)
HOUSEHOLD	NA (SEE B)	20 (508)	11 1/2 (292)	14 1/2 (368)	18 1/4 (464)

inch
(mm)

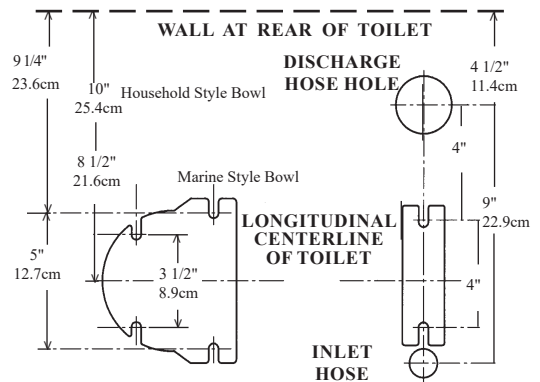
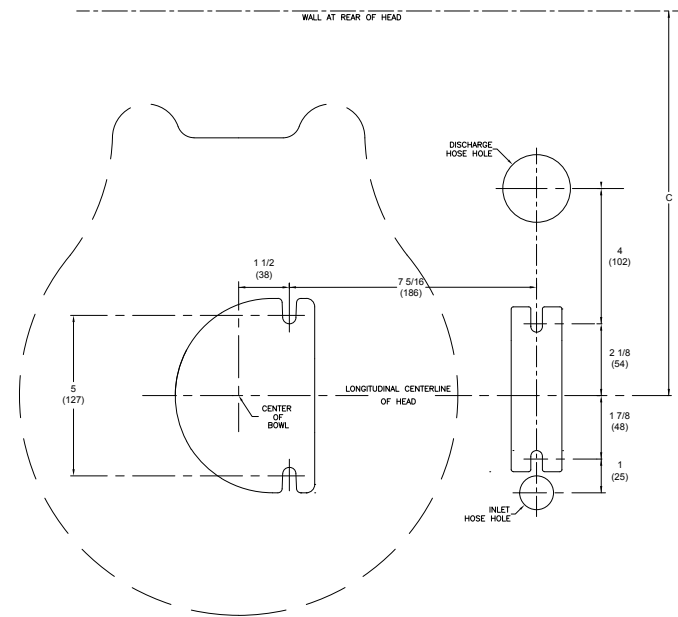

MOUNTING TOILET

Mounting surface must be flat and solid.

1. Install seat on toilet.
2. Place toilet where it will be located.
Make sure there is room to route hoses.
Make sure seat will open properly.
3. Mark location of toilet base mounting holes on mounting surface.
4. Drill holes for toilet mounting bolts/screws.
5. Secure toilet to surface.

NOTE: Never mount PHEII where it may be subject to shower spray or other sources of external water.

PLUMBING

WARNING: HAZARD OF FLOODING

Toilets mounted at or below the waterline, at greatest angle of heel, and connected to a Seacock/Thru Hull Fitting(s) **MUST** have **VENTED LOOPS** installed in toilet discharge plumbing and between raw water intake pump and toilet bowl.

Install vented loops per manufacturer's instructions. Double clamp all below-waterline connections.

IMPORTANT

- Fittings and 90° bends should be kept to a minimum.
- In-Line Strainer may be installed on Sea Water Models per Installation Instructions. This will prevent clogs.
- Discharging untreated sewage is forbidden in all U. S. waters within the three-mile limit.
- Thru-hull fittings and seacocks must be installed where they are easily accessible.
- Use only quality reinforced hoses such as Raritan Saniflex (SFH)
- Secure all hoses properly.

1. Route discharge hose above discharge outlet with a vented loop. This will enable the toilet to discharge more efficiently and will help to prevent backflow.
2. An In-Line Strainer (#163000) is recommended. This will help minimize odors and help prevent clogging.
3. Intake and discharge thru-hull fittings should be located far enough apart to prevent discharge water from being drawn through the intake.
4. The optional Raritan Knocks Out Odors Kit (#KO2) permits use of Cleans Potties (#1PCP22) with the PHII and PHEII toilets. Raritan Cleans Potties deodorizes the bowl and lubricates internal parts.
5. Flush and check for leaks.

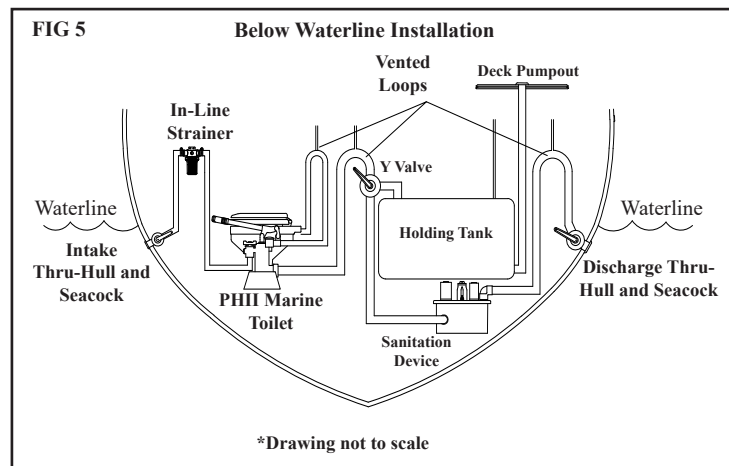
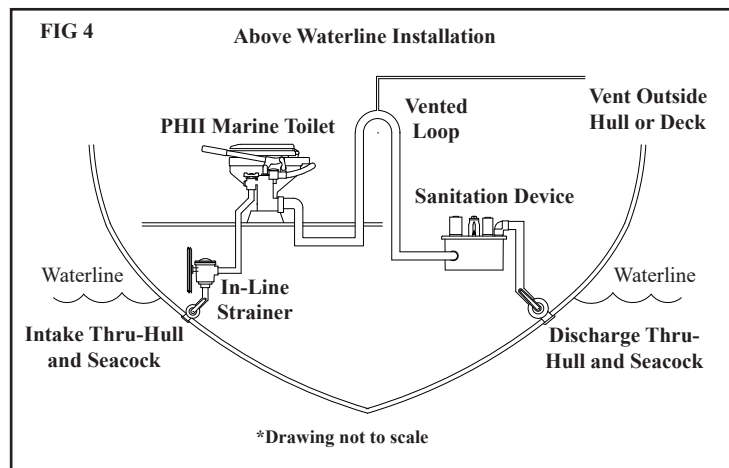

ELECTRIC CONVERSION KIT INSTALLATION (PHECKII) - For PHII Models Only

NOTE: It is recommended that the toilet be removed before installing the PHECKII.

1. Close the seacocks.
2. Remove cotter pin (#1210A) and handle (#1208W) from toilet. Disconnect hoses and unbolt toilet from deck.
3. Align connecting rod in track on side of pump housing and place motor-gearbox unit in position on base (#1248W) between pump and bowl.
4. Insert four hex head screws (#1119A) with lock washers (#1118). Tighten evenly.
5. Insert bolt (#1115) through connecting rod (#1116BW) and thread into yoke (#1211PL). Tighten jam nut (#1115A) securely; this connection is not a pivot point.

WIRING

WARNING: Hazard of Shock and Fire

- Always use proper wire, wire connectors and fuse/circuit breaker. See Specification Chart.
 - Secure wire properly.
 - Do not connect appliances to toilet circuit.
 - Make sure power is off before proceeding.
 - Use proper wire terminals for all wire connections.
1. Determine proper wire size by measuring distance from:
 - Power Source to push-button to toilet motor and back to power source.
 2. Select proper wire and fuse/circuit breaker size from Specifications on Installation page.
 3. Install fuse/circuit breaker in positive line at source.
 4. Connect positive wire from fuse/circuit breaker to Push Button Switch.
 5. Connect wire from Push Button Switch to orange wire on motor(s).
 6. Connect wire from battery negative or power source ground buss to black wire (negative) on motor(s).

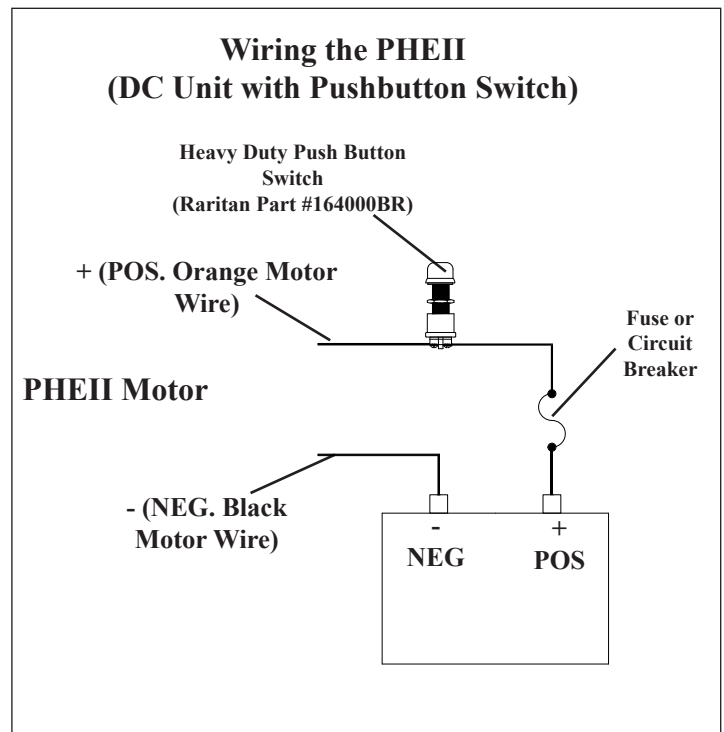

Water not being drawn in

- **Check Ball Stuck**
Shutoff seacock and remove intake hose
Using an eraser end of pencil be sure check ball is moving freely
- **Debris lodged in intake valve body**
Check and clean valve body
- **Piston O-ring worn**
Replace Piston O-ring
- **Inlet valve in wrong position**
Inlet valve should only rotate 1/4 turn

Leak around piston shaft

- **Cartridge seal worn**
Replace cartridge seal
Inspect and replace piston shaft if scored

Odor comes from head area when flushed

- **Marine vegetation lodged in bowl**
Remove bowl and attach pressure water at spud assy.
Install strainer in intake line
- **Intake water is foul (most common in salt and brackish)**
Install Knocks Out Odors Kit (KO2) to help deodorize intake water
- **Back pressure from holding tank**
Tank full or vent clogged, inspect and clean
- **Permeated discharge hose**
rub with warm damp rag if smell transfers to rag
replace hose

Water accumulates in the bowl too fast

- **Flapper valve not seated properly**
Close intake valve and pump dry - clean or replace flapper valve as necessary
- **Joker valve not closing or opening properly**
Clog or restriction in discharge line
Close intake valve and pump dry - clean or replace joker valve as necessary

Not enough water to rinse bowl

- **Intake valve positioned improperly**
Be sure inlet knob only turns 1/4 see fig. #3
- **Debris around intake or discharge check balls**
Remove check balls, clean and replace as necessary
- **Scored pump housing or worn piston "O" ring**
Inspect inside of housing replace "O" ring and housing as necessary
- **Intake line or strainer clogged**
Clean line and strainer

Water rises in bowl

- **Vented loop(s) not breaking siphon**
Close discharge seacock, then intake seacock to determine which is causing the problem. Clean or replace vented loop(s) parts.
- **Joker valve worn**
Inspect, clean or replace as needed

Electric motor labors or manually hard to pump

- **Low voltage at motor while running**
Check condition of batteries, terminals and wire connections for corrosion. Check gauge of wire to be sure it is not undersized.
- **Holding tank vent clogged or tank full**
Clean holding tank vent or empty tank
- **Discharge line obstructed**
Test by putting a short piece of hose on discharge fitting and pump into bucket if OK then - Check thru-hull fitting and hose for clog
- **MSD Clogged**
Test as above if OK - then see the MSD instruction manual
- **Discharge seacock closed**
Open discharge seacock

Units requiring extensive repairs may be returned to the Millville, NJ or Fort Lauderdale, FL office for overhaul. Instructions, including name, address and phone number MUST accompany returned units to ensure proper handling.

See additional FAQ's at:
www.raritaneng.com/tech-support/faq

**PARTS FOR RARITAN PHII AND PHEII
MARINE TOILET**

<u>Part No.</u>	<u>Description</u>
1115	3/8"-16 x 1 1/2" Hex Head S/S Bolt(2)
1124	1/4"- 20 x 1/2" R.H. Machine Screw
1200CW	Pump Housing
1201	Intake and Discharge Valve Ball (2)
1202	Intake and Discharge Valve Gasket (2)
1203BW	Intake Valve Body w/"O" Rings, (Includes 1203B, 1203B1, 1203B2, 1203B3)
1203W	Air Valve Assembly
1204B	Intake Valve Cap
1208W	Retractable Handle
1209BW	Valve Handle
1210	Handle Socket
1210A	Cotter Pin
1210B	Cotter Pin (3)
1211PL	Piston Rod Yoke
1212W	Piston Rod Assembly w/"O" Ring (1232MS)
1213W	Piston Rod Seal Assembly, Pre-6/92, (Includes 1213A, B, C, D)
1213A	"U" Cup Seal (Pre-6/92)
1213B	Delrin Washer (Pre-6/92)
1213C	Snap Ring (Pre-6/92)
1213D	White Neoprene Washer (Pre-6/92)
1214W	Piston Shaft Seal Cartridge Assy (1214, 1214A, 1214B) Fits pumps mfg. after 6/92
1216	Clevis Pin (3)
1217	Discharge Valve Cap
1218	Fulcrum Link (2)
1222AW	90° Discharge w/Flange (Std.)
1222B	Straight Discharge (Opt.)
1223B	Flange Nut 3/8"-16 S/S (2)
F098	Housing Screw 1/4"-20 x 1" S/S (4)
1226B	Nut, 1/4"-20 S/S (8)
1228CW	Flapper Valve Assembly (1/2" Holes)
1232MS	Piston "O" Ring
1234	Bowl Gasket
1236E	Bowl Elbow
1238SC	Marine Style Seat and Cover - Slow Close
1245SC	Household Style Seat and Cover - Slow Close
1246W	Base Cover (2 pcs.)
1248W	Base w/Plug
1249	Base Plug
1250W	Base and Cover Assy.(1246W and 1248W)
C253	Joker Valve
CH42	Hose (3/4" I.D.)
CH43P	Hose Clamp (2)
F005	1/4"- 20 x 5/16" S/S Socket Set Screw
F081	Bowl Bolt 1/4"-20 x 2 S/S Hex head
LWS	Intake and Discharge Valve Spring (2)
RNI	Nylon Shoulder Washer

PARTS FOR ELECTRIC DRIVE

<u>Part No.</u>	<u>Part Name</u>
1100W	Gear Box Housing Assembly
1102	Worm
1104	Ball Bearing
1105	Snap Ring
1106AS	Rubber Connection w/Sleeve

<u>Part No.</u>	<u>Description</u>
1106W	Coupling w/Sleeve, complete
1108A	Motor Mounting Nut (2)
1109*	Motor (12, 24, 32, 120V DC)
1110	"O" Ring
1112	Link
1113	Link Pin, Worm Gear Pin
1115	3/8" - 16 x 1 1/2" Hex Head S/S Bolt
1115A	3/8" - 16 Hex Jam Nut S/S
1116BW	Connecting Rod Assy. (1116B, 1114B, 1114D)
1117B	Crank Bolt
1118	Lock Washer (4)
1119/1119A	Hex Head Screw (4)
1120W	Worm Gear Assy.(1111, 1113, 1120)
1122	"O" Ring
1123	Gear Box Cover
1124	1/4"- 20 x 1/2" R.H. Machine Screw(4)
M23A	#10 Lockwasher S/S (2)

PHC PARTS

<u>Part No.</u>	<u>Description</u>
1226A	Housing Screw 1/4"-20 x 1 1/4" S/S (4)
1226C	Plastic Spacer Washer (4)
1301PW	Toilet Base Assembly (1301P, 1343)
F081	Bowl Bolt 1/4"- 20 x 2" S/S Hex head

RARITAN INSTALLATION ACCESSORIES

<u>Part No.</u>	<u>Description</u>
163000	In-Line Strainer
164000BR	Push button switch
1PCP22	C.P., Cleans Potties, Bio-enzymatic, 22 oz.
CHTII	Compact holding tank - 5 gallon
SFH	Sani-Flex Hose
SL1CC	Super Lube 1cc tube
KO2	Knocks Out Odor Kit
TD90319	Vented Loop 3/4"
TD90323	Vented Loop 1 1/2"
TD90314W	"Y" Valve

BOWL & SEAT

<u>Part No.</u>	<u>Description</u>
1236AW	Spud assy.
1237W	Marine-size Bowl assy.
1244W	White Household-style Bowl assy.
1238SC	Marine-size seat & cover; Slow Close
1245SC	Household-style seat & cover; Slow Close
VCAP	Vinyl Cap

OVERHAUL KITS

<u>Part No.</u>	<u>Description</u>
PHRKII	PHII&PHEII-U-cup Seal (mfg.before 6/92)
PHRKIIC	PHII&PHEII-Cartridge Seal (mfg.after 6/92)
PHIIPUMP	PHII Pump replacement assembly

*Specify Voltage

EXPLODED PARTS VIEWS, PHII MARINE TOILET AND PHECKII ELECTRIC CONVERSION UNIT

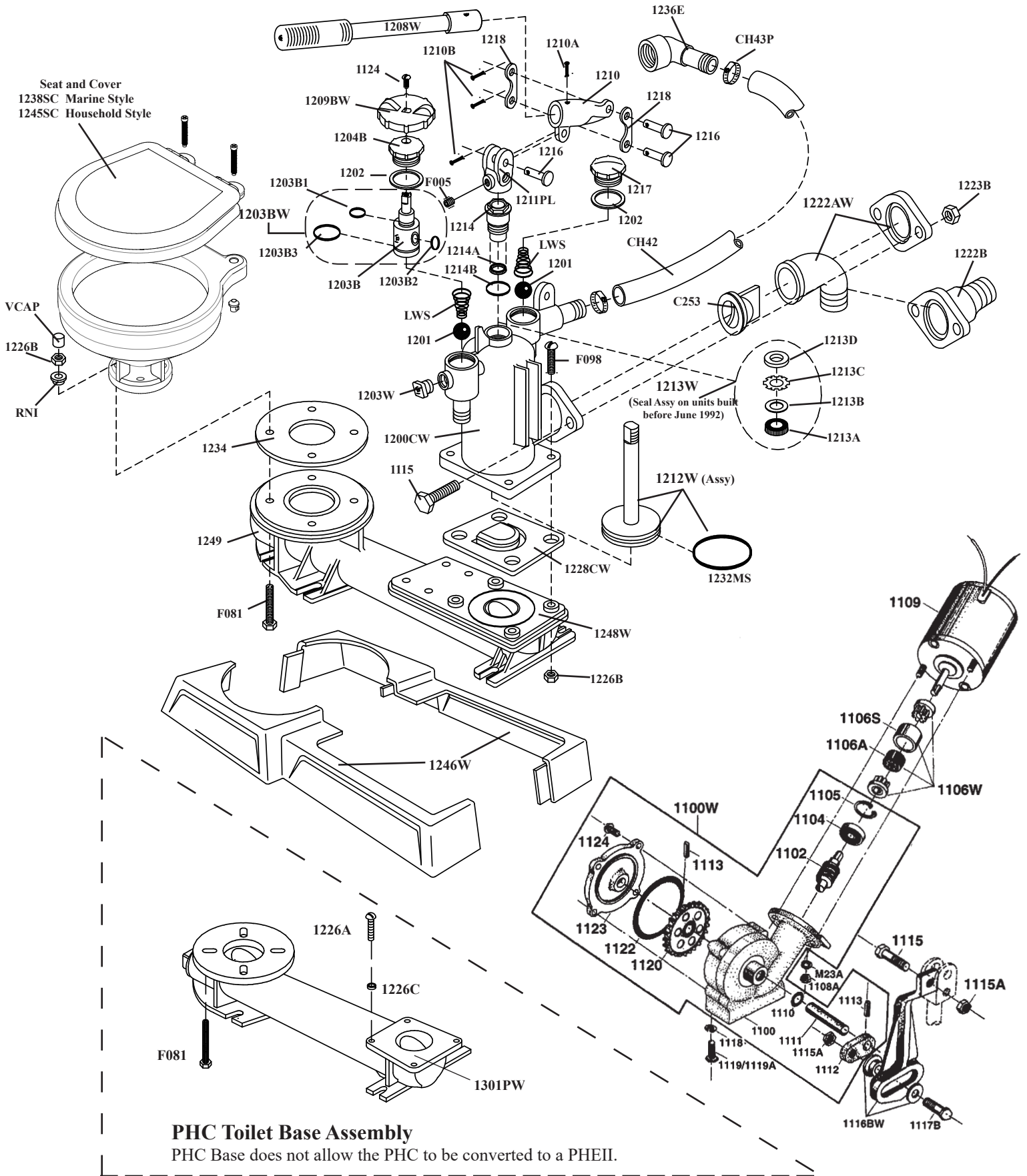

PHII Housing Identification & Replacement

Note: 1200CW style pump housings use repair kit part# PHRKIIC. Units manufactured prior to June 1992 (1200W housing) use repair kit part# PHRKII.

The Pump assembly 1200CW is a direct replacement for the 1200BW older PHII Pump housing. The 1200CW utilizes a replaceable seal cartridge assembly which if worn is easily replaceable.

The Former 1200W housing when worn at the seal bushing area required a whole housing replacement. Units manufactured prior to June 1992 utilize the 1200BW housing.

The PHRKII (Pre-1992) Repair Kit Includes:

- 1201: 3/4 Valve Ball (2)
- 1202: Valve Cap Gasket
- 1203BW: Intake Valve Body w/"O" Rings
(includes: 1203B, 1203B1, 1203B2, 1203B3)
- 1213W: Piston Rod Seal Assy
(includes: 1213A, 1213B, 1213C, 1213D)
- 1226C: Plastic Spacer Washer (4)
- 1228CW: Flapper Valve Sub-Assy.
- 1232MS: Piston Multiseal O-Ring
- 1234: Bowl Gasket White
- C253: Joker Valve
- RNI: Nylon Shoulder Washer (4)
- SL1CC: Super Lube: 1cc Packet (3)



The PHRKIIC (Post 1992) Repair Kit Includes:

- 1201: 3/4 Valve Ball (2)
- 1202: Valve Cap Gasket (2)
- 1203B1: Inlet Valve O-Ring
- 1203B2: Inlet valve Body O-Ring
- 1203B3: Inlet Valve Bottom O-Ring
- 1214W: Piston Shaft Seal Cartridge Assembly
(includes: 1214, 1214A, 1214B)
- 1226C: Plastic Spacer Washer (4)
- 1228CW: Flapper Valve Assembly
- 1232MS: Piston Multi-Seal O-Ring
- 1234: Bowl Gasket (White)
- C253: Joker Valve
- RNI: Nylon Shoulder Washer (4)
- SL1CC: Super Lube: 1cc Packet (3)



Inlet Valve/ Handle Orientation and Repair

Tools you will need:

Channel type pliers.

Flatblade (med) screwdriver

Gaining access to the inlet valve

To clean out debris or dismantle the valve it is necessary to access the inlet valve spring (part# LWS) and ball (#1201).

It is only necessary to unscrew the inlet valve cap (part #1204B) approximately 5 revolutions with channel type pliers. *Note: It is not necessary to remove or loosen any other part.*

Then by grasping the 1209BW handle and gently lifting upwards, the entire assembly (down to part #1203BW) can be removed.

Clean out any debris in this area.

Replace gasket (part#1202) if necessary and apply a small amount of Super Lube (#SL1CC) to the O-ring area of the 1203BW.

Reassemble in the reverse order making sure that the alignment post of the 1200CW housing protrudes **between** the two limiting stops in the underside of the 1209BW. This allows for the proper position of the inlet valve. If installed properly this creates a maximum of a 1/4 turn from "Dry" to "Flush" **not** 3/4 turn.

Note: Do not overtighten #1204B as gasket #1202 will displace

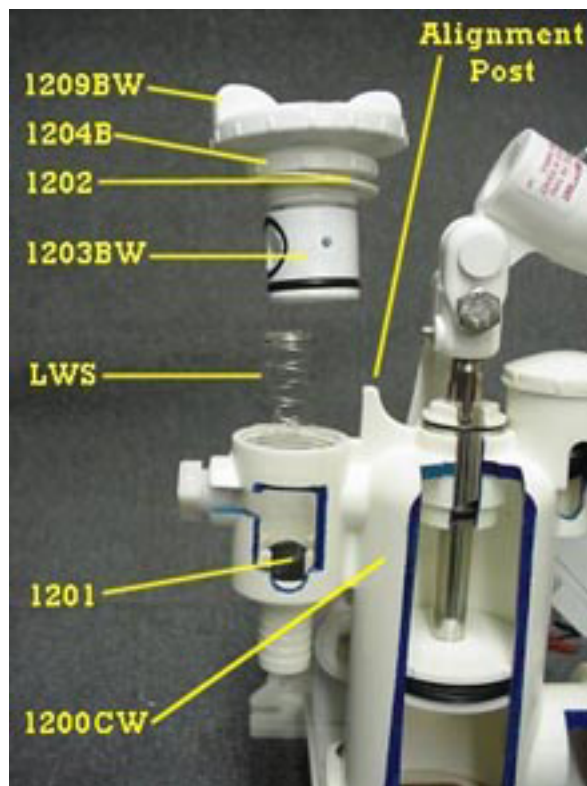
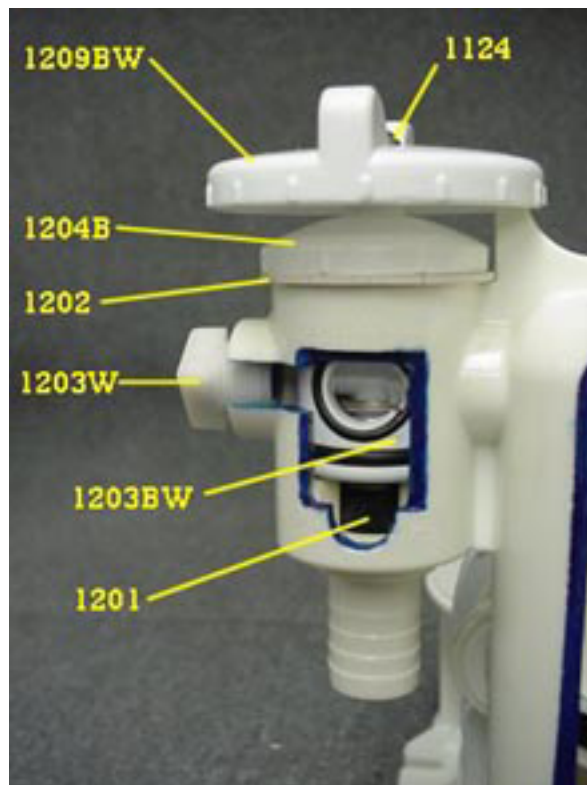

LIMITED WARRANTY

Raritan Engineering Company warrants to the original purchaser that this product is free of defects in materials or workmanship for a period of one year from the product's date of purchase. Should this product prove defective by reason of improper workmanship and/or materials within the warranty period, Raritan shall, at its sole option, repair or replace the product.

1. TO OBTAIN WARRANTY SERVICE, Consumer must deliver the product prepaid, together with a detailed description of the problem, to Raritan at 530 Orange St., Millville, N.J. 08332, or 3101 SW 2nd Ave. Ft. Lauderdale, FL 33315. When requesting warranty service, purchaser must present a sales slip or other document which establishes proof of purchase. THE RETURN OF THE OWNER REGISTRATION CARD IS NOT A CONDITION PRECEDENT OF WARRANTY COVERAGE. However, please complete and return the owner Registration Card so that Raritan can contact you should a question of safety arise which could affect you.
2. THIS WARRANTY DOES NOT COVER defects caused by modifications, alterations, repairs or service of this product by anyone other than Raritan; defects in materials or workmanship supplied by others in the process of installation of this product; defects caused by installation of this product other than in accordance with the manufacturer's recommended installation instructions or standard industry procedures; physical abuse to, or misuse of, this product. This warranty also does not cover damages to equipment caused by fire, flood, external water, excessive corrosion or Act of God.
3. ANY EXPRESS WARRANTY NOT PROVIDED HEREIN, AND ANY REMEDY FOR BREACH OF CONTRACT WHICH BUT FOR THIS PROVISION MIGHT ARISE BY IMPLICATION OR OPERATION OF LAW, IS HEREBY EXCLUDED AND DISCLAIMED. ALL IMPLIED WARRANTIES SUCH AS THOSE OF MERCHANTABILITY AND OF FITNESS FOR A PARTICULAR PURPOSE, IF APPLICABLE, AS WELL AS ANY IMPLIED WARRANTIES WHICH MIGHT ARISE BY IMPLICATION OF LAW, ARE EXPRESSLY LIMITED TO A TERM OF ONE YEAR. SOME STATES DO NOT ALLOW LIMITATIONS ON HOW LONG A LIMITED WARRANTY LASTS, SO THE ABOVE LIMITATION MAY NOT APPLY TO YOU.
4. UNDER NO CIRCUMSTANCES SHALL RARITAN BE LIABLE TO PURCHASER OR ANY OTHER PERSONS FOR ANY SPECIAL OR CONSEQUENTIAL DAMAGES, WHETHER ARISING OUT OF BREACH OF WARRANTY, BREACH OF CONTRACT, OR OTHERWISE. SOME STATES DO NOT ALLOW THE EXCLUSION OR LIMITATION OF INCIDENTAL OR CONSEQUENTIAL DAMAGES, SO THE ABOVE LIMITATION OR EXCLUSION MAY NOT APPLY TO YOU.
5. No other person or entity is authorized to make any express warranty, promise or affirmation of fact or to assume any other liability on behalf of Raritan in connection with its products except as specifically set forth in this warranty.
6. This warranty gives you specific legal rights, and you may also have other rights which vary from state to state.



530 Orange Street, Millville, NJ 08332 USA
Telephone: 856-825-4900 FAX: 856-825-4409
www.raritaneng.com

Fort Lauderdale, FL
Telephone: 954-525-0378