

FLUSH HANDLE CONTROL FOR ATLANTES FREEDOM™ TOILET VORTEX-VAC™ Installation and Maintenance Instructions

THE FOLLOWING ARE CAUTIONARY STATEMENTS THAT MUST BE READ AND FOLLOWED DURING BOTH INSTALLATION AND OPERATION.

WARNING: *Raritan Engineering Company, Inc. recommends that a qualified person or electrician install this product. Equipment damage, injury to personnel or death could result from improper installation. Raritan Engineering Company, Inc. accepts no responsibility or liability for damage to equipment, injury or death to personnel that may result from improper installation or operation of this product.*



WARNING: HAZARD OF SHOCK OR FIRE



Always use recommended fuse, circuit breaker and wire size.

DO NOT install in the area requiring “Ignition protected” devices.

FLUSH LEVER POSITIONS

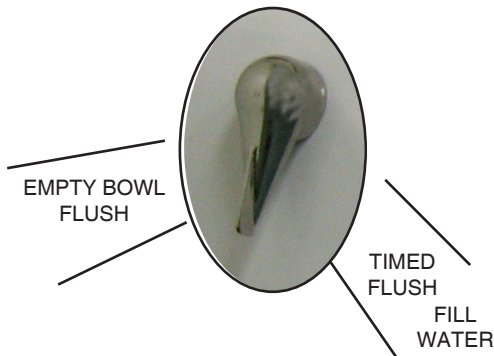

Pull Handle



Push Handle

Description: “02” model:

The 02 model is designed to work as a momentary unit using only microswitches to activate the motors. It is also a “fail safe” mode for the toilet control in the 03 model.

“03” model:

The “03” model contains a smart toilet control which provides timed operation while still having momentary functionality if toilet control is removed.

Operation:

Pull Handle Forward:

Model 03 - Pull handle forward and release: starts a timed flush, intake pump starts followed by discharge pump.

Model 02 - Pull handle forward and hold to add water.

Push Handle Backward:

In both models runs just the discharge pump for a “dry bowl” flush.

If vessel is equipped with a Marine Sanitation Device and you want to start the MSD from Toilet Control:

03 Models: Electrosan or Purasan EX, see respective manuals.

02 Models or other MSD (such as Purasan, LectraSan MC,...) Call Raritan Customer Service or visit www.raritaneng.com

NOTES: for Wiring

- Distances are from source to unit and back to source.
- Distance from power source to remote intake pump MUST be included when determining total distance. Same wire size MUST be used for lower base and remote intake pump.
- Recommended conductor wire minimum AWG (mm²) for 3% voltage drop.
- Recommended conductor sizes are based on 105°C rated insulation. Single conductor (not bundled), refer to ABYC Standards for sizes with other insulation ratings.
- For 120/240 VAC units, use 12VDC specifications from transformer to unit.

CONVERSIONS

Wire - AWG to mm²

AWG	16	14	12	10	8	6	4	2
mm ²	1.5	2.5	4.0	6.0	10.0	16.0	25.0	35.0

Feet to Meters

Feet	10	15	20	25	30	40	50
Meter	3.1	4.6	6.1	7.6	9.2	12.2	15.2

Recommended Wire and Fuse/Circuit Breaker Sizes

Table1-Sea Water Model

Units Voltage	Circuit Breaker/fuse size (amps)	Toilet Dis-charge Amps draw	Remote Pump Only Amp draw	10 feet	15 feet	20 feet	30 feet	40 feet	50 feet
12 VDC	30	18	10	10 AWG	8 AWG	6 AWG	4 AWG	4 AWG	2 AWG
24VDC	20	10	5	16 AWG	14 AWG	12 AWG	12 AWG	10 AWG	8 AWG

Table 2- Pressurized Freshwater Model

Units Voltage	Circuit Breaker/fuse size (amps)	Amp draw	10 feet	15 feet	20 feet	30 feet	40 feet	50 feet
12 VDC	25	18	10 AWG	10 AWG	8 AWG	8 AWG	6 AWG	4 AWG
24 VDC	15	10	16 AWG	16 AWG	14 AWG	12 AWG	10 AWG	10 AWG

Table 3 - Remote Intake Pump Only (Seafresh)

Units Voltage	Circuit Breaker/fuse size (amps)	Amp draw	10 feet	15 feet	20 feet	30 feet	40 feet	50 feet
12 VDC	15	10	14 AWG	12 AWG	10 AWG	10 AWG	8 AWG	6 AWG
24 VDC	10	5	16 AWG	16 AWG	16 AWG	16 AWG	14 AWG	12 AWG

WIRING

WARNING: Hazard of Shock and Fire

- Always use proper wire, wire connectors and fuse/circuit breaker. See Specification Chart.
 - Secure wire properly.
 - Do not connect appliances to toilet circuit.
 - Make sure power is off before proceeding.
- Determine proper wire size by measuring distance from:
 - Power Source to toilet and back to power source.
 - Remote pump units - also include distance from power source for remote pump to remote pump and back. Same wire gauge must be used for both discharge and remote pump.
 - Select proper wire and fuse/circuit breaker size from Specifications on specification page.
 - Install fuse/circuit breaker in positive line at source.
 - Wire using Fig. 1, 2, 3, 4, 5, or 6

MOUNTING CONTROL 03 MODELS

Mounting control box:

- Locate a place for control box near toilet. Do not install box more than six feet away to avoid excessive volatage drop
- Route wires between toilet and control, *Cut all extra length of wires to keep voltage drop to minimum*

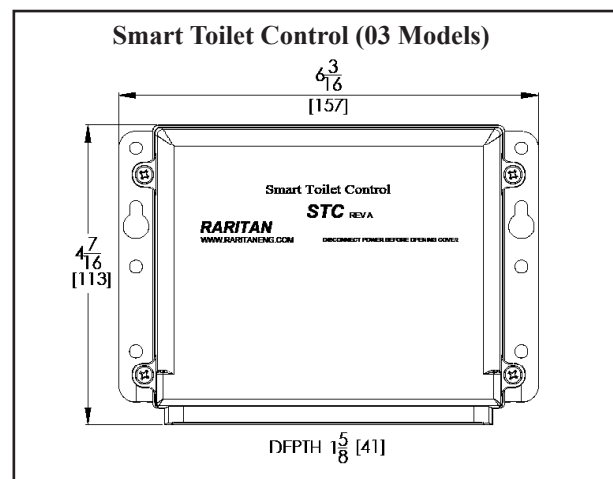

FIG 1 WIRING FOR MOMENTARY FLUSH HANDLE CONTROL REMOTE 02 MODEL

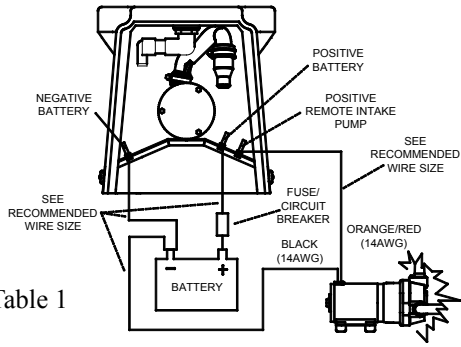

FIG 2 WIRING FOR MOMENTARY FLUSH HANDLE CONTROL FRESHWATER 02 MODEL

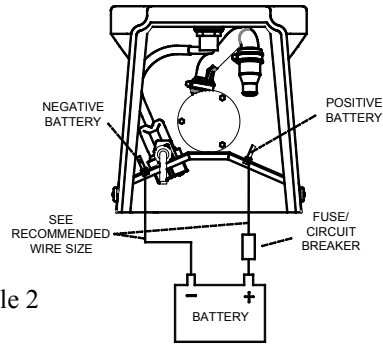

FIG 3 WIRING FOR FLUSH HANDLE CONTROL WITH SMART TOILET CONTROL FRESH WATER 03 MODEL

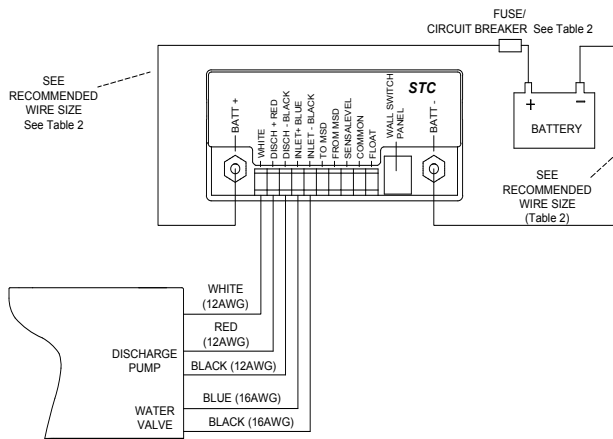

FIG 4 WIRING FOR FLUSH HANDLE CONTROL WITH SMART TOILET CONTROL WITH REMOTE PUMP 03 MODEL

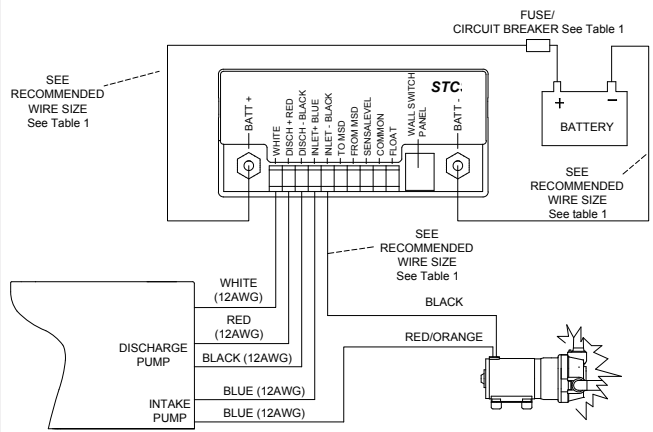

FIG 5 WIRING FOR FLUSH HANDLE CONTROL WITH SMART TOILET CONTROL SEAFRESH 03 MODELS

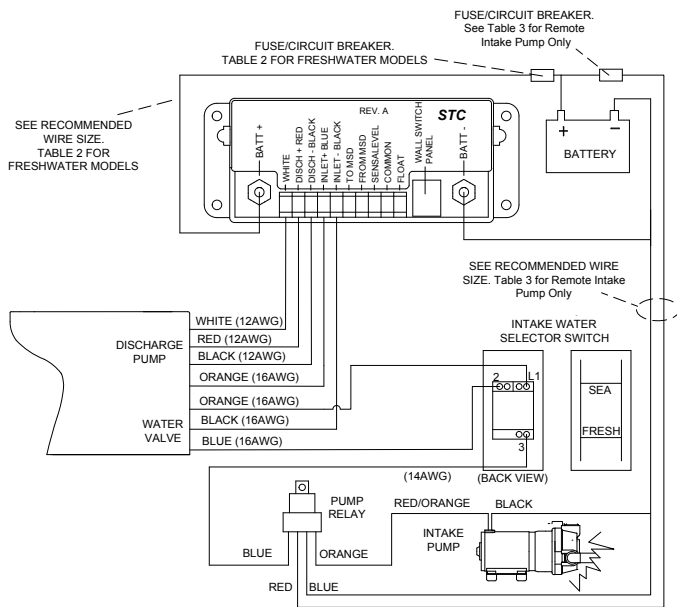
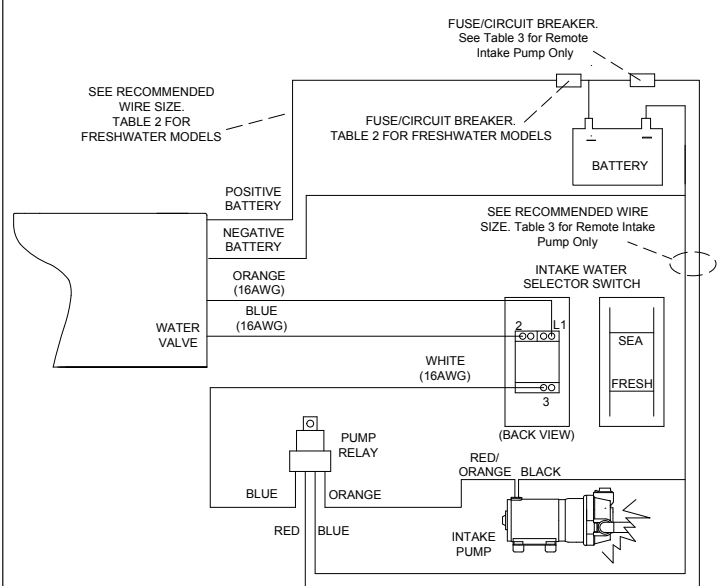

FIG 6 WIRING FOR MOMENTARY FLUSH TOILET CONTROL SEAFRESH 02 MODELS



PROGRAMMING OF FLUSH CONTROL

NOTE: Flush control is set at factory to work in most installations. Use following instructions to re-program if adjustment on water levels and timings are needed.

NOTE: Jumper setting must be changed from 1 to 2 to allow for programming. See FIG 7. After programming is completed, return jumper to "POSITION 1". Plug Programming Panel into controls Wall Switch Panel Jack using cable provided.

Programming timing for "NORMAL" flush cycle:

Normal cycle has initial fill time (T1), Discharge pump time (T2), and water retention fill time (T3). All three times (T1, T2 and T3) are programmable.

Factory setting:

T1= 3sec T2= 3sec T3= 2 sec

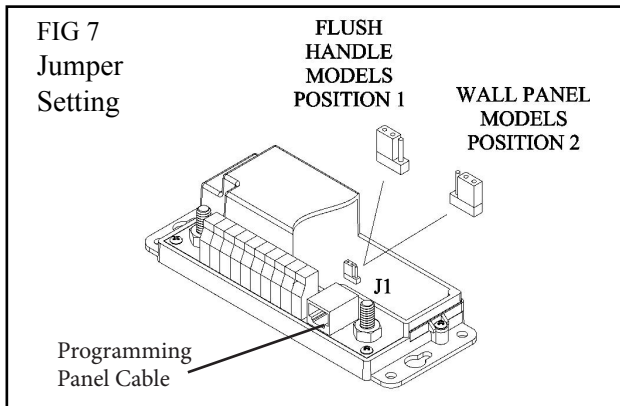

To change any of the above settings, re-programming is needed.

Step 1 – Placing the unit in program mode:

Hold the WATER ONLY & EMPTY buttons down together for three seconds. The Holding Tank Full LED will give three quick flashes indicating you have entered program mode - release both buttons.

Setting T1 initial fill time:

After placing the unit in program mode (Step 1 above) push the "Normal Flush" button the number of times required for the Water Valve/Inlet Pump time (one push= 2 sec's, two = 2 sec's., three= 3 sec's etc.) the Tank LED will flash once indicating a valid key push.

Note: If the button is pushed 9 times or more it will limit at 8 secs. Once this is done, push the EMPTY button to store this value (the unit will flash three times indicating the time has been set and you have left program mode)

Setting T2 Discharge Pump Time:

After placing the unit in program mode (Step 1 above) push the EMPTY button the number of times required for the Discharge Pump time (one push = 2 seconds, two= 2 secs, three =3 secs etc.) the Tank LED will flash once indicating a valid key push.

Note: If the button is pushed 9 times it will limits to 8 seconds . Once this is done push the NORMAL button to store this value (the unit will flash three times indicating the time has been set and you have left program mode).

Setting T3 Water retention fill Time:

After placing the unit in program mode (Step 1 above) push the WATER ONLY button the number of times required for the Water Valve/Inlet Pump time (one push = ZERO sec's, two = 2 secs. three = 3 sec's., etc.) the Tank LED will flash once indicating a valid limit to 8 sec.

Once this is done push the "NORMAL" button to store this value (the unit will flash three times indicating the time has been set and you have left program mode).

Programming the WATER ONLY Disable Features:

1. Hold the WATER ONLY & EMPTY buttons down together for three seconds. The holding tank full LED will give THREE flashes indicating you have entered program mode .
2. Push the WATER SAVER button. The WATER ONLY and EMPTY buttons now can be disabled or enabled:
3. Pushing the WATER ONLY button will disable both WATER ONLY and EMPTY buttons. The holding tank full LED will give THREE flashes indicating you have left program mode.

Repeat steps 1 to 3 to re-enable these buttons.

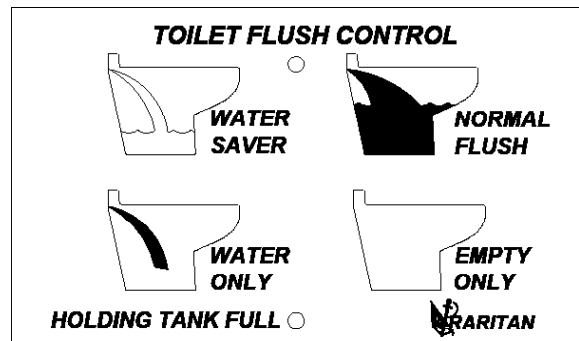

For limited warranty terms and conditions please refer to toilet manual



530 Orange Street,
Millville, NJ 08332 USA
Telephone 856-825-4900
Fax 856-825-4409

www.raritaneng.com

Southern Office and Plant:
3101 SW Second Avenue,
Ft Lauderdale, FL 33315 USA
Telephone 954-525-0378
Fax 954-764-4370